

The Analysis of Rush Orders Risk in Supply Chain: A Simulation Approach

Amr Mahfouz & Amr Arisha
3S Group, College of Business,
Dublin Institute of Technology (DIT),
Aungier Street, Dublin2, Ireland.
Amr.mahfouz@dit.ie amr.arisha@dit.ie

Abstract. Satisfying customers by delivering demands at agreed time, with competitive prices, and in satisfactory quality level are crucial requirements for supply chain survival. Incident of risks in supply chain often causes sudden disruptions in the processes and consequently leads to customers losing their trust in a company's competence. Rush orders are considered to be one of the main types of supply chain risks due to their negative impact on the overall performance. Using integrated definition modeling approaches (i.e. IDEF0 & IDEF3) and simulation modeling technique, a comprehensive integrated model has been developed to assess rush order risks and examine two risk mitigation strategies. Detailed functions sequence and objects flow were conceptually modeled to reflect on macro and micro levels of the studied supply chain. Discrete event simulation models were then developed to assess and investigate the mitigation strategies of rush order risks, the objective of this is to minimize order cycle time and cost.

1.0 INTRODUCTION

Due to the severe pressures that companies face with current volatile markets, satisfying customer demand has become an essential requirement for gaining higher market shares. In order to achieve customer satisfaction, companies tend to accept customer orders regardless of time and location constraints. Such acceptance of short lead time orders (i.e. rush orders) often causes many problems in managing supply chain network due to the operating priorities they take at the expense of regular orders. This situation results unbalance usage of system resources (i.e. consume more resources to deliver the rush order) which make companies face many troubles in delivering their regular orders at the required time and quality [15]. The equilibrium of both types of orders is a true challenge that every supply chain has to deal with. Arising from the aforementioned issues and the willingness to apply strategies that can reduce risks, this study aims to assess the impact of rush orders risk on supply chain performance and investigate different mitigation strategies that can decrease its influence. The management of supply chain risks is an inevitable task for corporations that seek to achieve substantial cost reductions and enhance operational efficiency. Simulation modeling approach has been successfully used in many applications as an effective analytical tool that it can be utilized to assess system performance and examine improvement strategies. For example, simulation was used to question the workload in health care systems [14], to schedule servers in semiconductor manufacturing systems [1] and evaluate customer segmentation in supply chain management [5]. These are few examples of many applications where simulation was effectively employed in modeling complex systems and examining various strategies to find the optimum solution. In the context of supply chain risk management, discrete-event simulation was developed to assess and mitigate multi-echelon supply chain disruption risks. Ref. [13] has illustrated that inventory level has a significant effect on

customer satisfaction in case of disruption occurrence. Vendor selection, as a main strategy for mitigating supply chain risks, was studied using simulation analysis approach. A simulation-optimization model was employed to reduce anticipated costs, increase quality acceptance level and achieve on time delivery by applying different vendor selection strategies [16]. Another common supply chain risk, transportation disruption, was modeled using system dynamics simulation to evaluate its effect on supply chain performance (e.g. inventory level and customer order delivery) [17]. Resilience, defined as the ability of a supply chain to reduce probabilities of disruption occurrence and system recovery time, has been developed further by applying "what-if" analysis methodology. Supply chain resilience to disruptions was also evaluated using simulation modeling approach [6]. Strategic, demand, market, implementation and performance risks are five risk categories that contain most of supply chain risks [4]. Recent studies now focuses on demand risk and has been studied from different perspectives, such as demand uncertainty, demand fluctuations and demand for new product [3] and [10]. The impact of rush orders on supply chain has not been researched extensively and has few if any published reports. As an important source of risk in current operation conditions, this study aims to assess the impact of rush orders on order's cost and cycle time. The developed simulation model will be used also to examine risk mitigation strategies against rush orders. FAB Company, a leading enterprise in office furniture, tends to accept any customer orders regardless its type (regular or rush orders) aiming to accommodate as many customers as possible and maintain their market share. FAB competes in a volatile market; hence price and lead time are key areas that companies must deliver on effectively. In the following sections, a brief introduction of the problems facing FAB is described, followed by a detailed explanation of the modeling process. Having described the conceptual model first, the

development of the simulation model followed by validation and verification process is than addressed. Finally, results and areas of discussion are presented.

2.0 PROBLEM STATEMENT

FAB supplies various products such as, staff desks, workstations, chairs, doors, curtain walls, floors, partitions, ceiling, cladding and many more products (i.e. over 2000 products). Along with these products, complete furnishing solutions are offered including; bank sectors, entertainment facilities (i.e. cinemas), tourism buildings (i.e. hotels) and the health care sector (i.e. hospitals). The company is a typical example of a multi-echelon complex supply chain (Fig. 1). Customer orders arrive in the form of individual contracts; each contract usually contains different product types with different quantities. Contracts are dispatched to singular products and parts which are designed by the design office (i.e. design tier). After that, products and parts designs are sent to research and development (R&D) to create the Bill of Materials (BOMs). Both drawings and BOMs are passed to the planning for; (1) checking the availability of in-stock raw materials, (2) issuing purchase orders for unavailable raw materials, (3) assigning factories' schedule to allocate required work orders. Once raw materials are available, manufacturing processes then start. Distribution centre staff then collects the final products from factories, which are packed and shipped to the end customer. The intense competition that FAB faces in today's market in addition to its desire to compete on a worldwide scale prompts them to shape their supply chain in Engineer-To-Order (ETO) structure and to accept both regular and rush orders. ETO structure usually increases the level of complexity in the relationship between the various entities of supply chain [7]. However it has to be used to create competitive leverage by producing customized products according to customer specifications (based on customer site layout and characteristics). On the other hand, accepting rush

orders protects the company market share by maintaining customer satisfaction which in turn creates a wider niche and extra profit margins. Nevertheless, rush orders might cause delay in delivering regular orders as they have priority in using available resources and raw materials. Given the complexity of FAB's supply chain and the large number of variables, entities and operations rules included, there is a great need to use an effective methodology to support FAB decision makers. Simulation modeling is used as a powerful tool that can handle such complexity and be used as an efficient risk assessment tool. FAB simulation models are developed with three different scenarios in order to assess rush order risk and to investigate different mitigation strategies to reduce risk's influence. Average cycle times and costs are the two main performance measures that are used in this study to achieve the following objectives:

- (1) Develop a simulation model for the FAB supply chain in order to model ETO complexity.
- (2) Use simulation models to assess the impact of rush orders on system performance.
- (3) Investigate new risk mitigation strategies against the current strategies and select the best regarding to the performance indicators.

3.0 RESEARCH METHODOLOGY

The research methodology encompasses various phases starting with adopting conceptual models, data collection, developing simulation models, validation and verification and ending with results analysis and discussion.

3.1. Conceptual Model

Integration definition model (IDEF) family has been used to conceptually model the FAB supply chain. Hierarchical structure of IDEF language allows users (e.g. strategic managers, operational engineers and system analyzers) to effectively understand the sequence and details of system's functions. IDEF language has different kinds of structures that can model systems with various purposes [12]. IDEF0

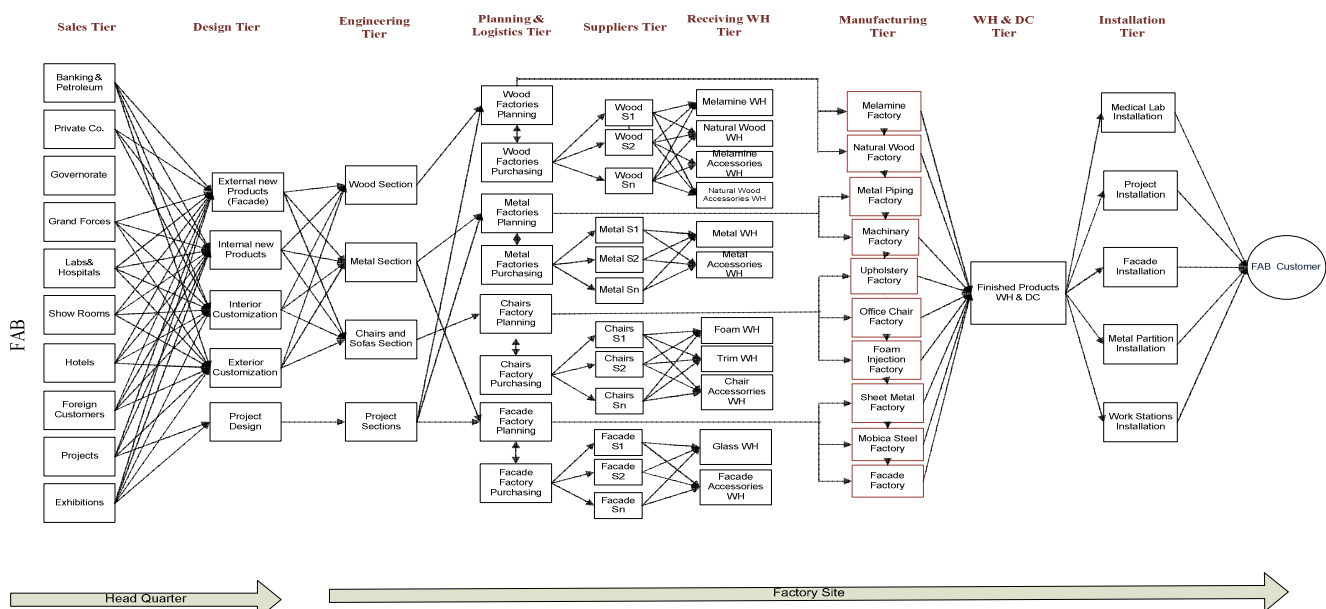

Figure 1 FAB Supply Chain structure

(i.e. functional modeling) and IDEF3 (i.e. process modeling) are most relative techniques for business process modeling task. The main difference between both techniques is that IDEF0 focuses more on how business functions are defined, sequenced and connected by their inputs and resources. On the other hand, IDEF3 is a more detailed modeling approach that represents the logical object's flow through system's processes [9]. In this study, IDEF0 and IDEF3 are integrated in order to model the complexity of FAB supply chain. The macro-level is modeled using IDEF0 showing the functions within FAB, their inputs, outputs, controls and resources (Fig. 3). On the other hand, IDEF3 is used to model the micro-level of FAB focusing on products flow and system's operational rules (Fig.4).

3.2. Modeling Macro-level Using IDEF0

An activity block, which is the main unit of IDEF0, describes the main functions of FAB supply chain. Inputs, outputs, mechanisms, and controls are represented by horizontal and vertical arrows (Fig. 2). In addition to input and output arrows, the mechanisms arrow shows resources that facilitate modeled functions (e.g. labors, machines, computer systems, etc...). Function control arrows (top arrow) can be company regulations, standards or legislation. Different kinds of orders are received by FAB's sales staff. Some of these orders, like projects and tenders, require a preparation of time plans and financial offers before issuing the contracts. The ordered products are classified into two main categories; Standard Products (products that were manufactured in the company before and all its details are available) and Special Products (products with new designs and specifications and no data available for them). Standard Products go directly to the planning

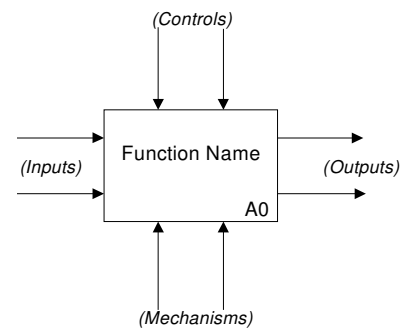

Figure 2 Basic IDEF0 construct

process in order to supply required materials and to issue factories' work orders. On the other hand, an engineering process starts by joining sales, design and R&D staff to design and identify Special Product's BOM. A detailed BOM is passed to the planning process again to supply required materials and issue work orders. After the production process, all products are collected according to their contract numbers and then delivered and installed at customer sites. Figure 3 graphically shows the main sequence of FAB supply chain processes, their inputs, outputs, and resources.

3.3. Modeling Micro-level Using IDEF3

In contrast to IDEF0, IDEF3 has less strict syntax and semantic rules. Integrating IDEF0 and IDEF3 using the hierarchical structure provides a detailed conceptual model for FAB. For example, Fig. (4) shows that the design and development function (A2) was split to more elaborated processes representing the main flow of design& development function. IDEF3 acts as a bridge between general conceptual model of FAB and proposed simulation model. In simulation model, processes blocks that are shown in IDEF3 model is considered as an activity blocks, whereas branching points will be represented as routing decisions.

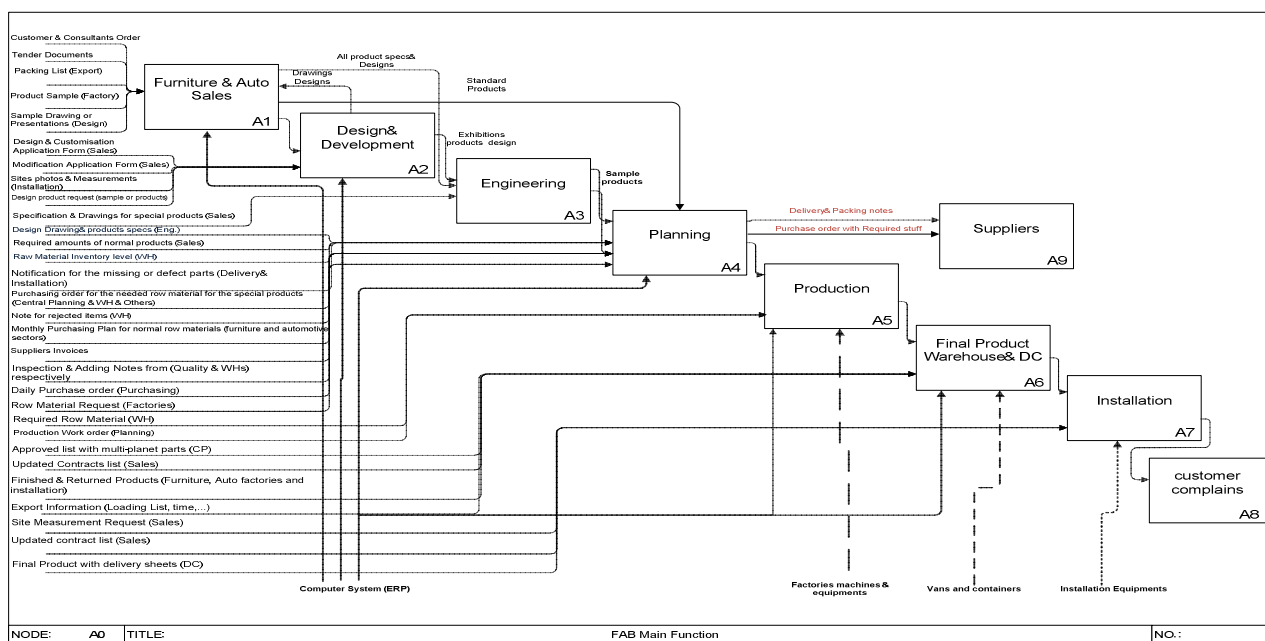

Figure 3 IDEF0 model for FAB supply chain

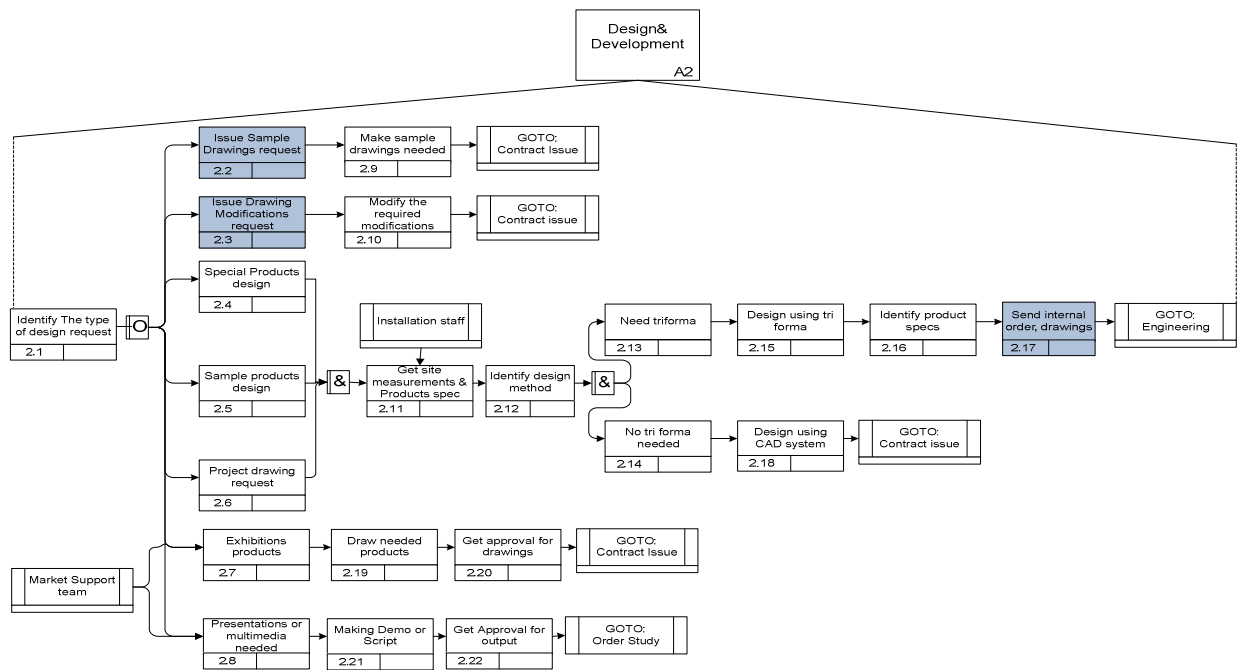

Figure 4 IDEF3 model for FAB supply chain

4.0 SIMULATION MODEL

Conceptual models (Fig. 3 and 4) provide a clear understanding of the relationships between different system entities. They also show the resources that are required at each step. Discrete-event simulation was employed to develop a detailed simulation model to mimic the process of FAB. Model assumptions are (i) no supplier disruptions are considered (ii) all received materials are accepted (no return of poor quality materials). The model was built and executed using simulation software based on Java and XML technology which provides object-oriented hierarchical and event-driven simulation capabilities for modeling large-scale applications. It also utilizes breakthrough activity-based modeling paradigms (e.g. real world activities such as assembly, batching, and branching). Many features in FAB are coded in the simulated blocks to mimic the real life application characteristics.

System entities are the objects (products) that are modified by resources (sales staff, design staff, supplier staff, etc...). Resources are characterized by their availability, whereas the product entity is characterized by arrival time, processing time, and product characteristics. Logical entities make decisions for creating, joining, splitting, buffering, and branching product entities. The model contains 950 blocks representing; queues, activities, and branching points. The hierarchical feature has been used to mimic exactly the system flow. Two main layers are developed; (1) the upper layer (i.e. macro level) which represents the main activities in FAB. Five main activities cover all simulated processes contain; sales and customer support, products design and engineering, resource planning and material management, manufacturing, and finally the warehouse and installation activity. These activities contain 13 processes that are conceptually modeled

by IDEF0 at Fig. (3) representing the core processes of FAB supply chain such as sales, contract issue, design, engineering, material management, ..., etc. (2) The lower layer (micro-level) illustrates the objects' flow of each process. IDEF3 was used to develop the conceptual model for this layer, where all operations rules are represented. An example of the lower layer modeling that illustrates inputs, outputs, and the relationships between some upper level processes is shown in Fig. (5). For the model to reach its steady state condition, the warm-up was 100 hours. Every simulation run represented a year of actual timing. In the experimental phase, the average from 10 replications of average cycle time and average operations costs were used as the main performance measures.

Table 1 shows the main input variables of FAB supply chain. Theoretical statistical distribution was utilized to represent the random patterns of input variables. The analysis of demand data resulted in normal distribution with a mean of 4 days and standard deviation of 1 day. Consistent with what was reported by [2], service time was fitted to exponential distribution since service time data are completely random. For production time weibull distribution was used. Finally, due to the shortage of lead time data that were supplied by FAB, gamma distribution was used, according to [8].

Table 1: Model input variables

Category	Input Variable
Customers	Orders arrivals
Suppliers	<ul style="list-style-type: none"> Lead time Incoming inspection time
Plants	Production time per product
Other Processes	Service time
Transportation	Time to ship between plant and head quarter

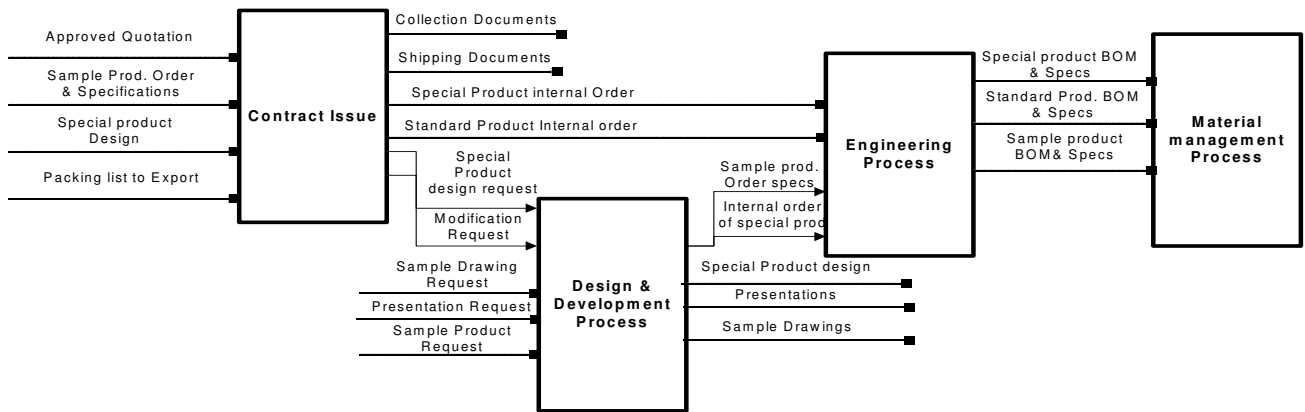

Figure 5 Example of micro level of the simulation model

4.1. Model Validation and Verification

In an effort to make the decisions that are based on simulation models more accurate, efficient methods of verification and validation (V&V) are needed. Inaccurate simulation results always lead to wrong decisions proposals and implementation, resulting in high costs that can be more than the total cost used for the simulation study. Therefore, the correctness and suitability of simulation results are very important. Different methods are used in order to verify simulation coding. Decomposition method (i.e. verify every group of blocks) was used to insure that every block functions as expected. A built-in simulation debugger is also used to avoid any coding bugs. On the other hand, validation process was considered as an integral process, which starts from input data collection through conceptual and simulation model development and ends at output data analysis. Out of 10 V&V methods that have been mentioned in [11], three validation methods have applied in three phases of this study; (1) data collection phase, (2) conceptual modeling phase and finally (3) simulation results phase. Three main objectives were targeted in the validation process of data collection phase; (1) no measurement errors in data collection process, (2) generated data have to match the pattern of historical data and (3) attribute values are within specified range. To achieve that, a detailed examination of data documentation's quality and consistency was done with the cooperation of FAB company staff. In addition, real data were compared with statistically generated data and results were approved by the IT department. The conceptual model was validated based on structured interviews with system managers and staff in order to be certain that all specified processes, structures, system elements, inputs and outputs are considered correctly. The modeling team also examined the accuracy and consistency of the conceptual model to the problem definition. After that, system performance indicators were revised with decision makers in order to be sure that it fits model objectives. Finally, two main approaches were used to validate the final simulation results. The first is "Face validation" approach that was performed by interviewing managers and manufacturing teams in order to validate simulation results. The second is

"comparison test", which is achieved by comparing the model and system output under identical input conditions. The validation process has shown that there is only 15% deviation between simulated and actual results.

5.0 RISK ANALYSIS

In this paper, risk analysis procedure contains two main phases. First, it focuses on assessing the influence of rush order risk on performance indicators. Second, risk mitigation strategies have been examined against current system configuration. Three simulation models were developed representing three operating strategies of FAB supply chain;

- (1) First Strategy (no rush order strategy): represents the current system configurations for FAB Company. No rush orders received, is the only assumption in this strategy.
- (2) Second Strategy (mixed orders strategy): represents current system configuration for FAB Company. Both regular and rush orders are expected in this strategy. The two orders' types have the same route through supply chain, however rush orders have higher priority for using resources and raw materials over regular orders.
- (3) Third Strategy (independent production route strategy): represents risk mitigation strategy which suggests a separate processing route for both rush and regular orders with dedicated resources for each of them. Ten simulation runs for no rush order and mixed orders strategies are illustrated at Table 2 and 3.

Table 2: Simulation results of no-rush order strategy

Strategy	Number of Replications	Orders Types			
		Regular Orders		Rush Orders	
		Cycle Time (days)	Cost (euro)	Cycle Time (days)	Cost (euro)
No rush orders strategy	1	31.44	7959.68	0	0
	2	25.66	7384.82	0	0
	3	29.32	7747.05	0	0
	4	29.84	7813.07	0	0
	5	29.10	8618.53	0	0
	6	27.23	7816.21	0	0
	7	26.81	7671	0	0
	8	28.00	7702.03	0	0
	9	38.87	8176.16	0	0
	10	30.85	8116.38	0	0

Table 3: Simulation results of mixed-order strategy

Strategy	Number of Replications	Orders Types			
		Regular Orders		Rush Orders	
		Cycle Time	Average Cost	Cycle Time	Average Cost
Mixed orders strategy	1	48.40	11074.44	22.22	9549.57
	2	37.00	9180.82	24.03	9134.61
	3	29.96	10433.74	21.44	7550
	4	35.61	10234.68	24.51	8511.3
	5	42.96	11076.76	27.38	9707.05
	6	31.83	10153.27	21.82	7353.75
	7	54.00	10856.41	23.78	8308.36
	8	61.75	11166.25	23.21	8225.44
	9	71.02	10495.88	27.66	9483.19
	10	37.65	9570.09	27.53	9352.08

Performance indicators were divided into two sections (regular and rush orders). No results are reported for rush order's columns in table 2 as no rush orders were allowed in this strategy. For the no rush order strategy, average cycle time of regular orders was ranged between 25 to 31 days, whereas average cost varies between € 7300 and € 8200 per order. Time and cost figures of regular orders were increased in the mixed orders strategy to record average cycle time between 30 to 70 days and average cost between € 9000 and € 11000 (Table 3). Table 4 shows the differences between the two strategies and indicates an increasing in average cycle time and average cost by 35% and 25% respectively in case of applying mixed orders

Table 4: Differences of performance indicators in applying first and second strategy

		Studied Strategies		Difference between 1st and 2nd Strategy
Order Type	Performance Indicator	No Rush Order Strategy	Mixed Order Strategy	Increased
Regular Order	Cycle Time	29.716	45.025	35%
	Average Cost	7900.493	10424.234	25%
Rush Order	Cycle Time	0	24.362	100%
	Average Cost	0	8717.535	100%

strategy. Out of these results, it can be concluded that receiving rush orders increases the values of average cycle time and average cost for regular orders. These negative results were generated as a result of the high priority that rush orders take over regular orders along all supply chain processes. Long waiting time, process interruptions and resources

Table 5: Simulation results of separate route strategy

Strategy	Number of Replications	Orders Types			
		Regular Orders		Rush Orders	
		Cycle Time	Average Cost	Cycle Time	Average Cost
Separate route strategy	1	34.00	8738.82	26.11	6799.42
	2	30.30	8866.41	25.22	6849.81
	3	27.37	8406.08	24.39	6520.65
	4	26.04	7600.91	22.99	6361.09
	5	26.02	8560.93	23.22	5988.47
	6	25.80	9006.65	22.39	5699.97
	7	31.95	9082.7	23.53	5764.3
	8	26.66	8423.42	23.80	6363.76
	9	28.28	8347.94	24.50	6805.84
	10	25.98	9149.19	23.06	6131.45

unavailability are the challenges that face regular orders in case of receiving rush orders. Inaccurate delivery time with high prices for regular orders are the results of rush orders risks under the current system configuration. In order to mitigate the influence of rush order's risk, a separate route strategy (strategy 3) is applied at design, engineering, planning, purchasing, production, and distribution centers. The simulation model was developed for risk mitigation strategy and was investigated against mixed orders strategy. Table 5 recorded a reduction in regular order's delivery time and average cost compared to mixed orders strategy (Table 3). Delivery time was alternated between 25 days to 34 days whereas average cost ranged between €7000 and €9000. The separate route strategy achieved a 37% reduction for regular order's delivery time and about a 17% reduction in average cost (Table 6). Results improvement has been achieved by separating the flow of rush and regular orders' causing a reduction in regular order's waiting time and cost. On the other hand, a reduction in rush order's cycle time and cost by 3% and 27% was noticed in case of applying separate route strategy. Applying the separate processing route strategy did not make a significant impact on rush orders' average cycle time, while average cost was significantly influenced. This can be explained that rush orders in both strategies did not stay in the processes' buffers for a long time. In the mixed order strategy, rush orders were located in the head of all buffers due to the high priority they have over the regular orders. Whereas in separate processing route strategy, orders are split into two processing flows causes a decrease in resources' utilization and hence declined the time of waiting free resources.

Table 6: Differences of performance indicators in applying second and third strategies

		Studied Strategies		Difference between 2nd and 3rd Strategy
Order Type	Performance Indicator	Mixed orders strategy	Separate route strategies	Decreasing
Regular Order	Cycle Time	45.025	28.245	37%
	Average Cost	10424.234	8618.305	17%
Rush Order	Cycle Time	24.362	23.926004	3%
	Average Cost	8717.535	6328.476	27%

6.0 CONCLUSION

Rush orders is a challenging risk for supply chains due to their nature of pre-emption over regular orders processing. Due to severe competition in current markets, enterprises have no longer an option not to consent rush orders, even with such inconvenient operating conditions that might include the restructuring of supply chain strategy. This often leads to the adoption of complex structures such as Engineer-To-Order (ETO). Simulation modeling has proven to be an effective tool to handle systems featuring high levels of complexity with uncertainty. Hence, simulation models were developed in order to

effectively assess the impact of rush orders risks on system performance indicators (cycle time and total cost). It was also used to investigate risk mitigation strategy that can decrease the negative impact of rush orders on FAB's supply chain performance. IDEF0 and IDEF3 were integrated to develop a detailed conceptual model of FAB's supply chain. IDEF language was used as it applies a standard format with hierarchical structure that supports the modeling of predecessors, relationships, inter-relationship and interdependences of activities and objects. Modeling has been structured into layers to be able to present the processes and their activities as well as the overall system view. Three methods of validation were applied for data collection phase, conceptual modeling phase and then simulation modeling results.

To assess and mitigate the impact of rush orders risk, this study focused on three strategies (i.e. no rush order strategy, mixed orders strategy, and independent route strategy). The simulation model provides not only numerical measures of system performance, but also insights about the effect of rush orders on the delivery time and the cost of regular orders. Results showed that rush orders have a negative impact on both cycle time and average cost of regular orders as they were increased by (35%) and (25%) respectively. The risk mitigation strategy - dedicate a separate route for rush orders- minimized the impact of rush orders by decreasing cycle time by 37% and cost by 17% for regular orders and 3% and 27% for rush orders.

7.0 REFERENCES

- 1- Arisha, A. and Young, P. (2004). "Intelligent simulation-based lot scheduling of photolithography toolsets in a wafer fabrication facility". *Proceedings of the 2004 winter simulation conference*.
- 2- Banks, J., Carson, J., Nelson, B. and Nicol, D. (2005). "Discrete Event System Simulation". 4/e: Pearson Prentice Hall, Upper Saddle River, NJ 07458.
- 3- Chen, X. and Zhang, J. (2008). "Supply chain risks analysis by using jump-diffusion model". *Proceedings of the 2008 winter simulation conference*.
- 4- Clouse, M. and Busch, J. (2003). "How to Identify and Manage Supply Risk". Supply Chain Planet October.
- 5- Chen, Y. and Xueping, L. (2009). "The effect of customer segmentation on an inventory system in the presence of supply disruptions". *Proceedings of the 2009 winter simulation conference*.
- 6- Falasca, M., Zobel C. and Cook. D. (2008). "A decision support framework to assess supply chain resilience".

Proceedings of the 5th international ISCRAM conference- Washington, SC, USA.

- 7- Gosling, J., and Naim, M. M. (2009). "Engineer-to-order supply chain management: A literature review and research agenda". *International journal of production economics 122: 741-754.*
- 8- Haddley, G. and Whitin, T. (1963). "Analysis of Inventory System". *New Jersey: Prentice Hall*
- 9- Mahfouz, A., Ali, S. and Arisha, A. (2010). "Practical simulation application: evaluation of process control parameters in twisted-pair cables manufacturing system". *Simulation modeling practice and theory 18: 471-482.*
- 10- Nagurney, A., Cruz, J., Dong, J. and Zhang, D. (2005). "Supply chain networks, electronic commerce, and supply side and demand side risk". *European Journal of Operational Research 164: 120-142.*
- 11 - Rabe, M., Spieckermann, S., and Wenzel, S. (2009). "Verification and validation activities within a new procedure model for V&V in production and logistics simulation". *Proceedings of the 2009 winter simulation conference*.
- 12- R.J. Mayer, C.P. Menzel, M.K. Painter, T. Blinn, P.S. Dewitte, Information Integration for Concurrent Engineering (IICE) IDEF3 Process Description Capture Method Report, Knowledge Based Systems Inc., College Station, TX, 1997.
- 13- Schmitt, J.A. and Singh, M. (2009). "Quantifying supply chain disruption risk using Monte Carlo and discrete-event simulation". *Proceedings of the 2009 winter simulation conference*.
- 14- Thorwarth, M., Arisha, A. and Harper, P. (2009). "Simulation model to investigate flexible workload management for healthcare and service escape environment". *Proceedings of the 2009 winter simulation conference*.
- 15- Van Donk, D.P. and Van der Vaart, T. (2005). "A case of shared resources, uncertainty and supply chain integration in the process industry". *International Journal of Production Economics 96: 97-108.*
- 16- Wu, D. and Olson, D. (2008). "Supply chain risk, simulation, and vendor selection. *International Journal of Production Economics 114: 646-655.*
- 17- Wilson, M. (2007). "The impact of transportation disruptions on supply chain performance" *Transportation Research Part E 43: 295-320.*

8.0 Acknowledgment

The authors thank the head of business process integration department in FAB Company and all his engineers for their cooperation.